

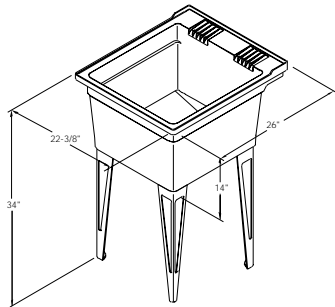

MS-2620-F



MS-2620-W



MULTI-PURPOSE SINK

- Single compartment, multi-purpose sink is manufactured from an innovative foam process.
- Polypropylene structural composite sink utilizes this unique molding process, producing seamless corners and edges while providing unrivaled strength.
- Floor-mounted units are equipped with coated steel, self-leveling legs.
- Available individually boxed, six-packed, or skid quantities of 24.

Model Number	Description
MS-2620-F	Floor Mounted Multi-Purpose Sink
MS-2620-W	Wall Mounted Multi-Purpose Sink**

**Wall-mounting brackets with hardware and filler panels included.

Options

Suffix	Description
-AP	Accessory Package
-DF1	Dual Handle Deck Faucet
-DF2	Single Lever Deck Faucet
-FA	Top Supplied Faucet Adaptor
-FP	Filler Panel
-PL	Polyethylene Legs
-TS	Top Supplied Faucet

Optional Colors

Suffix	Description
-AW	Appliance White
-BN	Bone
-BR	Burgundy
-HG	Hunter Green